

Physicochemical Basis of Fouling Prediction and Prevention in the Process Industry

G. Ali Mansoori

Department of Chemical Engineering, University of Illinois at Chicago
810 S. Clinton Street, Chicago, IL 60607-7000, U.S.A.

Abstract—In this report the physicochemical principles of deposition and fouling of heavy organics and other compounds are presented and discussed. The basic requirements for predictive modelling and mitigation of fouling in industrial processes are presented. The possible mechanisms of fouling in various processes are discussed in light of the general principles of fouling known and the available industrial processes fouling data. The various stages of fouling and the fouling prediction modelling requirements for those stages in industrial processes are specified and the data requirements for each stage are presented. Parameters influencing the fouling are specified and the foundations for predictive modelling, which will help to mitigate fouling and increase the useful life of processes, are specified.

Key Words: Fouling, Arterial blockage, Phase transition, Crystallization, Steric colloid formation, Micellization, Polymerization, Deposition, Precipitation

INTRODUCTION

One of the major unsolved complex systems confronting the chemical, petroleum, food and pharmaceutical industries at present is the untimely deposition of heavy organic and other solids dissolved or suspended in the fluid flow systems. The production, transportation and processing of chemicals, petroleum and other industrial fluids could be significantly affected by flocculation and deposition of such compounds in the course of industrial processing systems including transfer conduits, reactors and refinery and upgrading equipment with devastating economic consequences (Mansoori, 2000; Anthony et al., 2000; Karabelas, 1998; Mansoori, 1997; Mansoori, 2001; Mansoori, 1997).

One question of interest in the industry is “when” and “how much” fouling will occur under certain conditions. Since fouling-prone fluids generally consist of mixtures of highly asymmetric components it has become necessary to study the interactions among the mixture constituents as one of the possible major causes of fouling. The kind and amount of depositions from various complex fluid mixtures vary depending on the components present in them and the relative amounts of each family of compounds, which may be polydisperse. Because of this it may become necessary to develop analytic techniques to identify and measure the precipitates in a particular fouling process (Mansoori, 1997; Vasquez and Mansoori, 2000; Jiang and Mansoori, 1985; Panchal, 1997).

Concern about fouling / arterial blockage in the process industries has brought about a great deal of

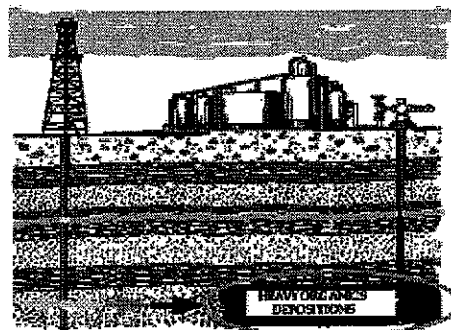

Fig. 1. An example of heavy organics deposition in petroleum production.

activity by the research and development organizations. As a result the research in this area of major concern to the industry has evolved from a rather artistic endeavor into a scientific approach through which one can now develop predictive and preventive measures for fouling as well as formulation of antifoulants (Ma, 2000; Muralidhara, 1996; Pereira, 1998). No doubt, inadequate data and information about the mechanism of a particular fouling has inhibited development of preventive steps that need to be taken in the design phase of systems with fluid flow. While for some widespread systems used in the industry, like heat exchangers (Panchal, 1997), the science of fouling prevention and mitigation is rather advanced, for most of the other sections in an industrial complex the science of fouling prediction and prevention is in its infancy. For example for the design of distillation columns the principles of distillation is well known (Wang and Mansoori, 1994), but the problem of fouling is rarely addressed in the literature related to distillation.

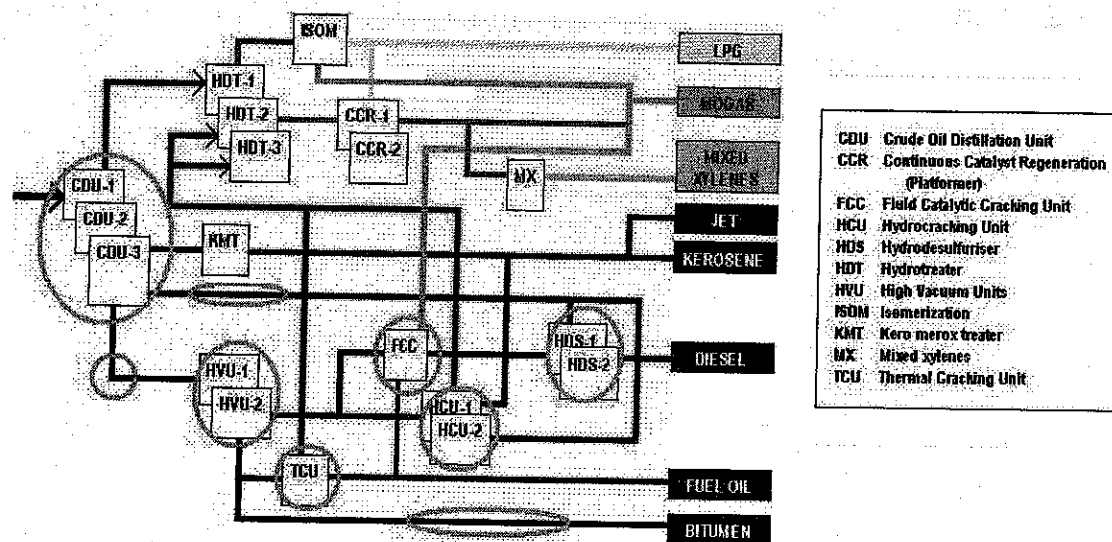

Fig. 2. Another example of heavy organics deposition in petroleum refining.

Three factors to be considered in the development of fouling mitigation and prevention in a particular system prone to fouling are the following (Mansoori, 2000):

- (1) Consideration of the fact that flow resistance due to fouling is a time-dependent and not a fixed-value.
- (2) Development of the capability to characterize / measure the conditions for the threshold / onset of fouling in a particular process.
- (3) Development of monitoring systems based on the true variables and mechanisms of fouling.

Remediation of the fouling deposits in the course of a continuous flow or process has been a costly undertaking and it has hampered the chemical and other process plant activities in many parts of the world. For example, heavy organics such as wax, resin, asphaltene, diamondoid and organometallic compounds may exist in a crude oil in various quantities and forms. Such compounds could precipitate out of the crude oil mixture due to various forces causing blockage in the oil reservoir, in the well, in the pipelines and in the oil production and processing facilities (Mansoori, 1997). Solid particles suspended in the crude oil may stick to the walls of the conduits and reservoirs. Heavy organics and solids deposition during oil production, transportation and processing is a very serious problem in many areas throughout the world (Escobedo, 1997). In the Prinos petroleum production field in North Aegean Sea, there were wells that, especially at the start of production, would completely cease flowing in a matter of a few days after an initial production rate of up to 3,000 BPD. The economic implications of this problem were tremendous considering the fact that a problem well workover cost could get as high as a quarter of a

million dollars. In Venezuela the formation of heavy organics (asphaltic sludges) after shutting in a well temporarily and/or after stimulation treatment by acid has resulted in partial or complete plugging of the well. At the Hassi Messaoud field, Algeria, deposit of heavy organics in the tubing has been a very serious production problem.

Heavy organics precipitation, in many instances, carries from the well tubing to the flow lines, production separator, pumps, strainers and other downstream equipment. Heavy organic materials deposited into the production installations of Mexico's oil fields have caused many operational problems as it is elaborated in reports by Escobedo, et al. (1997). For example, in the fields of Tecomonacan and Jujo depositions in many wells have caused numerous shut-downs and necessity of rather expensive aromatic washes. Heavy organics deposition in the North Sea and in the Gulf of Mexico oil fields in recent years have caused several under-sea pipeline pluggings with substantial economic loss to the oil production operations (Mansoori, 1997; Mansoori, 1997; Escobedo, 1997; Park, 1988; Georgiadis, 2000).

WAYS TO MINIMIZE FOULING

Deposition materials prone to fouling can be controlled using various mechanical and chemical treatment techniques including (Mansoori, 2000):

- (1) changes in shear,
- (2) elimination of incompatible materials from streams,
- (3) variation of pressure-drops in the facility and
- (4) minimization of mixings of incompatible streams during transfer processes.

STAGES OF FOULING PREDICTIVE AND PREVENTIVE MODELING

In developing predictive models for fouling the following two stages must be followed (Mansoori, 2000):

- (1) In the first stage analyses of all the data / information available for fouling in a particular industrial process from the point of view of their appropriateness for fouling predictive modeling.
- (2) Generation of additional data, if necessary, which can reveal the nature of fouling in the particular process under consideration.
- (3) Development of mechanisms of fouling and modeling of that for the purpose of generating predictive software which could be used to predict fouling.
- (4) Verification of the accuracy of the software versus industrial fouling data and possible modification and improvement in the developed mechanisms, models and the software.

PERFORMANCE DATA ANALYSIS

In order to model and predict the industrial processes fouling problems it is first necessary to understand what is happening and what are the causes and effects of fouling. To achieve this it is necessary to carefully examine and evaluate all the data and operating conditions at various plants in order to understand what are the variables which are effective on fouling and what are the mechanisms of such a phenomena. The objective of these efforts will be always to minimize the fouling clean up / remediation shutdown frequency of the plants and reduce the cost by making the minimum modification in the processes (Karabelas, 1998; Mansoori, 1997).

The possibility of whether the fouling material is a part of the feed to the system or it is a product of reaction / aggregation / flocculation in the system must be clarified. The role of various operating conditions in the system on fouling (pressures, temperatures, compositions, flow rates, etc. and their variations) must be understood and quantified. Only with appropriate modelling considering all the possible driving forces and mechanisms of fouling one may be able to predict the nature of fouling in each case and develop mitigation techniques to combat that.

The available fouling history data would be useful to test the packages, which will be developed. Considering the diversity of the data care must be taken in their analysis for any universality conclusions. However, in order to make comparisons between fouling data from various plants and test the

accuracy of the developed packages it will be necessary to acquire the compositions data of the feed in each plant as well as characteristics and conditions of operations of the process system used in those plants. Only then one can test the accuracy of the models developed and understand why in one case there is fouling and no fouling in another case.

MECHANISMS OF FOULING

While all the foulings are predominantly due to phase separation of a solid/condensed phase from a fluid (gas or liquid) phase, their mechanisms and driving forces are quite different and some times quite unique. Generally, complex fouling problems are a result of a combination of several phase transitions and reactions. To solve such problems (to model and predict them accurately) it is necessary to clearly understand their mechanisms and the interactive natures of phenomena involved. The first stage of study in any industrial processes fouling modeling is to understand what is the mechanism of such fouling(s).

In principle, research has indicated that nine different mechanisms may be responsible for all foulings where ever they may occur and they include (Mansoori, 2000; Anthony et al., 2000; Muralidhara, 1996; Park, 1988; Lawrence, 2000; Sahin, 2000):

- (1) Sedimentation of suspended solids (as shown in the following figure).



Knowing the properties of the fluid and suspended solid, flow conditions and mixing effects one can develop models to predict sedimentation of solids from liquids (Sheriff, 2001).

- (2) Solidification / crystallization due to phase change as a result of lowering the temperature and/or super-saturation. Examples of such cases are foulings due to paraffin / wax and diamondoid crystallization (Vasquez, 2000) (as shown in the following figures).

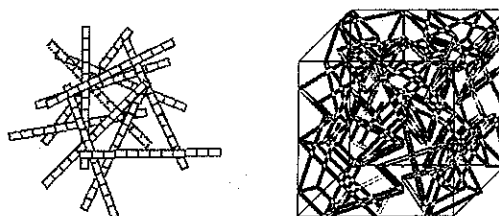

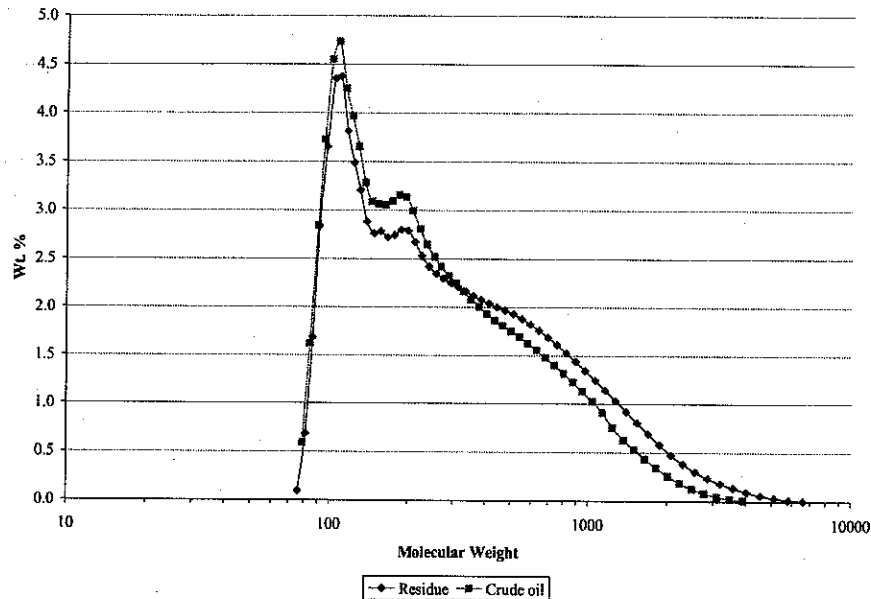

Fig. 3. Molecular weight distribution curves obtained by GPC for a whole crude oil and its residue.

Theories of freezing /melting can be applied to predict solidification, freezing point in the case of pure substances and cloud point and pour points in the case of mixtures (Mansoori, 1969; Himran, 1994; API, 2000).

(3) Solubility effect causing deposition / precipitation - For example, petroleum fluid is a mixture of various polydisperse compounds. The molecular weight distribution curves for a whole crude oil and its residue are shown in Fig. 3. A solubility balance among all such components makes a petroleum fluid stable. Changes in that balance can cause precipitation from a petroleum fluid and as a result fouling.

Theories of polydisperse polymer mixtures and solutions can be used to predict foulings due to solubility effect (Mansoori, 1997; Park, 1988; Du, 1986).

(4) Interfacial effect: Adsorption, wettability reversal, dehydration, surface active agents, foaming.



Theories of adsorption and wettability reversal can (as shown above), in principle, be applied to predict such foulings (Kim,1990).

(5) Aggregation / flocculation such as the aggregation and flocculation of asphaltene molecules in petroleum fluids due to decrease in polarity of the oil medium (as illustrated below).

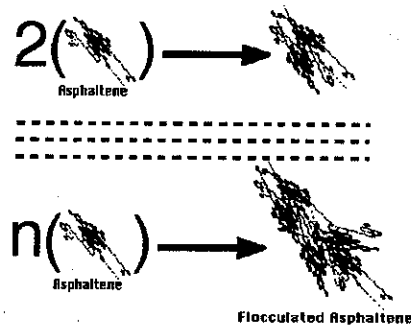

Kinetic theories of aggregation and flocculation can be used to predict foulings of this nature (Mansoori, 1997; Park, 1988).

(6) Colloidal effect such as the formation of asphaltene steric colloids formed as a result of a combination of asphaltene flocs and resins in petroleum fluids (as illustrated below).

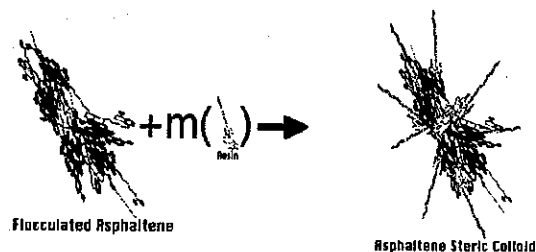

Theories of steric colloidal formation and colloidal formation and collapse (Mansoori, 1997; Park, 1988) are applicable for prediction of this category of foulings.

(7) Chemical reactions including polymerization and corrosion

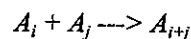

There is a wealth of information available

about this category of fouling models, which depend on the kind of compounds, and the possible catalytic effects involved.

(8) Electrokinetic effect such as the breakage of colloids and adsorption of macromolecules to the inner wall in electrically charged pipelines (Mansoori, 1997)(shown below).



(9) Biological phenomena such as the growth of anaerobic and aquatic micro- and macro-organisms and plants (as shown below).



A dramatic recent example of such foulings is the one due to Zebra Mussels infestation in the Great Lakes of the United States (Army Corps of Engineers, 1996). Some of the biological fouling cases are modeled. Generally such models are based on the experimental observations and measurements associated with each case.

One or more of the above effects / mechanisms listed above could be responsible for fouling in an industrial processes.

STAGES OF FOULING

The next step in industrial processes fouling modeling about which one must have information are the stages that such foulings go through (Mansoori, 2000):

(1) The first stage in modelling of industrial processes fouling is the need for full knowledge about the industrial processes, the microstructure, chemical composition, porosity, permeability, wettability, size(s) / size distributions, surface to volume ratio and any other relevant information which may have a role on fouling.

(2) The second stage in every fouling phenomena is the migration (or diffusion) of fouling material to the site where the fouling occurs. In a special case of knowing the nature of fouling it will be possible to develop a diffusion model for the process.

(3) The third stage of every fouling mechanism is the nucleation (initiation) of the fouled site. This matter

must be modeled using nucleation phenomena and with the appropriate knowledge about the data / parameters of the nucleating (fouling) material.

(4) The fourth stage in fouling modeling is the attachment stage. This stage is a function of the interfacial properties of the fouling material and the wettability of the surface where the fouling is going to occur. Appropriate data for these properties must be generated and with the application of interfacial theories this stage of fouling for the Industrial processes would be modeled.

(5) Upon the attachment of fouling material on a site, the phenomena of growth and its rate must be studied to be able to predict the time period of complete blockage by a certain fouling material. This stage will be a function of the nature of fouling material, other components present in the system and such other variables as temperature, flow rate and composition of the flow.

(6) After completion of the above stages the phenomena of erosion, aging and hardening must be studied. The fact that some of the reported foulings seem to be regenerable, initially and not in later times is indicative of the phenomena of aging and / or hardening taking place. There is a need for estimation methods of erosion; aging and hardening that would take hold.

Provided all the above stages of fouling are well understood and they are modeled a predictive package of fouling prediction could be developed.

PARAMETERS INFLUENCING FOULING

In the discussion presented above we have introduced the research and developmental activity necessary in order to generate predictive models for industrial processes fouling and the kind of information and data needed to set the mechanism(s) and quantify the fouling process. The ultimate result of such an R&D activity should consist of a comprehensive model for particular industrial processes fouling prediction. However, in order to predict the behavior of fouling material in a given process application of the following data about the system under consideration will be necessary (Mansoori, 2000):

(1) Fluids and solids physicochemical properties and their variations during the industrial processes under consideration. The literature has a wealth of theoretical approaches for prediction and calculation of physicochemical properties (API, 2000; Du, 1986; Kim, 1990; Army Corps of Engineers, 1996; Lan and Mansoori, 1977; Chen, 1987; Hwang and Mansoori, 1994). Such physicochemical properties of the necessary compounds may include density, viscosity, diffusivities, thermal and electrical conductivities of components, dynamic and static pour points, surface and interfacial properties, cloud point, thermal and

chemical stabilities of components of flowing fluids, compatibility of components with one another and with the industrial processes surfaces, colloidal stability factors including various threshold (onset) points. The requirement to know all the feed compositions entering into the system, and information on the immediate upstream processing step before recommending a particular preventive measure or mechanism of fouling for modeling purposes. Knowing the components of the incoming flow(s) it is generally possible to develop estimation methods for these properties based on the available experimental, correlations and theoretical techniques in the literature (Mansoori, 2001).

(2) Impurities present in the fluids and their role on the fouling phenomena. It is known that trace contaminants (like O₂, NH₃, H₂S, CN⁻, HCN, Hg, heavy-HCs, unsaturates, organic sulphides, chlorides, etc) have a significant effect on the performance of a certain chemical process fouling, and these need to be quantified. Since industrial processes applied in most commercial plants generally have foulings in much higher levels than in well-controlled laboratory tests the role of impurities may need to be quantified.

(3) With the availability of the above mentioned data it would be possible to develop a comprehensive industrial process fouling prediction package. Then one can make the necessary changes in the temperature, pressure, velocity / flow rate, etc. in the system in order to minimize fouling occurrence in any particular processes duty.

CONCLUSION

Generally a project of gaining a thorough understanding of the fouling problem in an industrial process and then generating a predictive-preventive model for it is quite challenging. Development of a predictive package for fouling mitigation in industrial processes can impact significantly our ability to understand and prevent fouling opposite the relevant process parameters and the morphology of technology. It is interesting to note that the total annual cost of tubing / pipeline fouling in the United States is estimated at \$18. billions per year. Attempts to predict and prevent fouling will be economically much more rewarding than having to deal with untimely replacement of major components which could have, both, adverse economic and downtime effects (Mansoori, 2000; Panchal, 1997; Georgiadis, 2000; Zhu, and Elimelech, 1997).

REFERENCES

- Anthony, E. J., R. E. Talbot, Jia and D. L. Granatstein, "Agglomeration and Fouling in Three Industrial Petroleum Coke-Fired CFBC Boilers due to Carbonation and Sulfation," *Energy Fuels*, **14**, 5, 1021 (2000).
- API, *API Basic Petroleum Data Book*, Am. Petrol. Soc., Washington, D. C. (2000).
- Army Corps of Engineers, *Handbook for Zebra Mussel Control*, U.S. Government Publication (1996).
- Chen, L. J., J. F. Ely and G. A. Mansoori, "Mean Density Approximation and Hard Sphere Expansion Theory: a Review," *Fluid Phase Equilib.*, **37**, 1 (1987).
- Du, P. C. and G. A. Mansoori, "Phase Equilibrium Computational Algorithms of Continuous Mixtures," *Fluid Phase Equilib.*, **30**, 57 (1986).
- Escobedo, J., G. A. Mansoori, C. Balderas-Joers, L. J. Carranza-Becerra and M. A. Mendez-Garcia, "Heavy Organic Deposition during Oil Production from a Hot Deep Reservoir: a Field Experience," *Proceedings of the 5th Latin American and Caribbean Pet. Eng. Conf. and Exhib.*, Rio de Janeiro, Brazil, 30, August -3, September (1997).
- Georgiadis, M. C., L. G. Papageorgiou and S. Macchietto, "Optimal Cleaning Policies in Heat Exchanger Networks under Rapid Fouling," *Ind. Eng. Chem. Res.*, **39**(2), 441 (2000).
- Himran, S., A. Suwono and G. A. Mansoori, "Characterization of Alkanes and Paraffin Waxes for Application as Phase Change Energy Storage Medium," *Energy Sources*, **16**, 117 (1994).
- Hwang, C. A. and G. A. Mansoori, "A New Analytic Statistical Mechanical Model for Polar Fluids," *Trends in Chemical Physics*, **3**, 33 (1994).
- Jiang, T. S. and G. A. Mansoori, "Asphaltene Deposition and its Role in Enhanced Oil Recovery Miscible Gas Flooding," *Proceedings of the 3rd European Conference on Enhanced Oil Recovery*, Rome, Italy, April (1985).
- Karavelas, A. J., "Comprehensive Modeling of Precipitation and Fouling in Turbulent Pipe Flow," *Ind. Eng. Chem. Res.*, **37**(4), 1536 (1998).
- Kim, S. T., M. E. Boudh-Hir and G. A. Mansoori, "The Role of Asphaltene in Wettability Reversal," *Proceedings of the 1990 Annual Convention of the Society of Petroleum Engineers*, SPE Paper # 20700 (1990).
- Lan, S. S. and G. A. Mansoori, "Statistical Thermodynamic Approach to the Prediction of Vapor-Liquid Equilibria Properties of Multi-Component Mixtures," *Int. J. Eng. Sci.*, **15**, 323 (1977).
- Lawrence, J. E., J. Grant, M. A. Quilliam, A. G. Bauder and A. D. Cembella, "Colonization and Growth of the Toxic Dinoflagellate *Prorocentrum Lima* and Associated Fouling Macroalgae on Mussels in Suspended Culture," *Marine Ecology Progress Series*, **201**, 9, 147 (2000).
- Ma, H., C. N. Bowman and R. H. Davis, "Membrane Fouling Reduction by Backpulsing and Surface Modification," *J.*

- Membr. Sci.*, **73**, 2, 15, 191 (2000).
- Mansoori, G. A. and F. B. Canfield, "Variational Approach to Melting," *J. Chem. Phys.*, **51**(11), 4967 (1969).
- Mansoori, G. A., "Thermophysical Behavior and Control of Fouling Materials in Petroleum Processing," *Proceedings of "Heat Exchanger Seminar" Lecture 1, 18 pages, AIChE (Chicago Section) and ASME International (Chicago Section)*, Chicago, IL, February 9 (2000).
- Mansoori, G. A., "Deposition and Fouling of Heavy Organic Oils and Other Compounds," *Proceedings of the 9th International Conference on Properties and Phase Equilibria for Product and Process Design, (PPEPPD 200)* May 20-25, Kurashiki, Okayama, JAPAN (2001).
- Mansoori, G. A., "Modeling of Heavy Organics Depositions," *J. Petrol. Sci. Eng.*, **17**, 101 (1997).
- Mansoori, G. A., "Prevention and Remediation of Heavy Organics Deposits in Petroleum Fluid Transfer Lines," *Proceedings of the International Conference on Fluid and Thermal Energy Conversion '97*, ISSN 0854-9346, K17-K39 (1997).
- Muralidhara, H. S., "Electrokinetics Methods to Control Membrane Fouling," *Ind. Eng. Chem. Res.*, **35**(4), 1233 (1996).
- Panchal, C. B., ed., *Fouling Mitigation of Industrial Heat Exchange Equipment*, Begell House, New York, NY (1997).
- Park, S. J. and G. A. Mansoori, "Aggregation and Deposition of Heavy Organics in Petroleum Crudes," *J. Energy Sources*, **10**, 109 (1988).
- Pereira, C. J., "Design of a Monolith Catalyst for Fouling Resistance," *Ind. Eng. Chem. Res.*, **37**, 2, 388 (1998).
- Sahin, A. Z., S. M. Zubair, A. Z. Al-Garni and R. Kahraman, "Effect of Fouling on Operational Cost in Pipe Flow due to Entropy Generation," *Energy Convers. Manage.*, **41**(14), 1485 (2000).
- Sheriff, O. M. and R. Gehr, "Laboratory Investigation of Inorganic Fouling of Low Pressure UV Disinfection Lamps," *Water Qual. Res. J. Can.*, **36**(1), 71 (2001).
- Vasquez, D. and G. A. Mansoori, "Identification and Measurement of Petroleum Precipitates," *J. Petrol. Sci. Eng.*, **26**, 1-4, 49 (2000).
- Wang, J. L. and G. A. Mansoori, "A Revision of the Distillation Theory," *Scientia Ir.*, **1**, 3, 267 (1994).
- Zhu, X. and M. Elimelech, "Colloidal Fouling of Reverse Osmosis Membranes, Measurements and Fouling Mechanisms," *Environ. Sci. Tech.*, **31**(12), 3654 (1997).

(Manuscript Received May 29, 2001)

